

TA

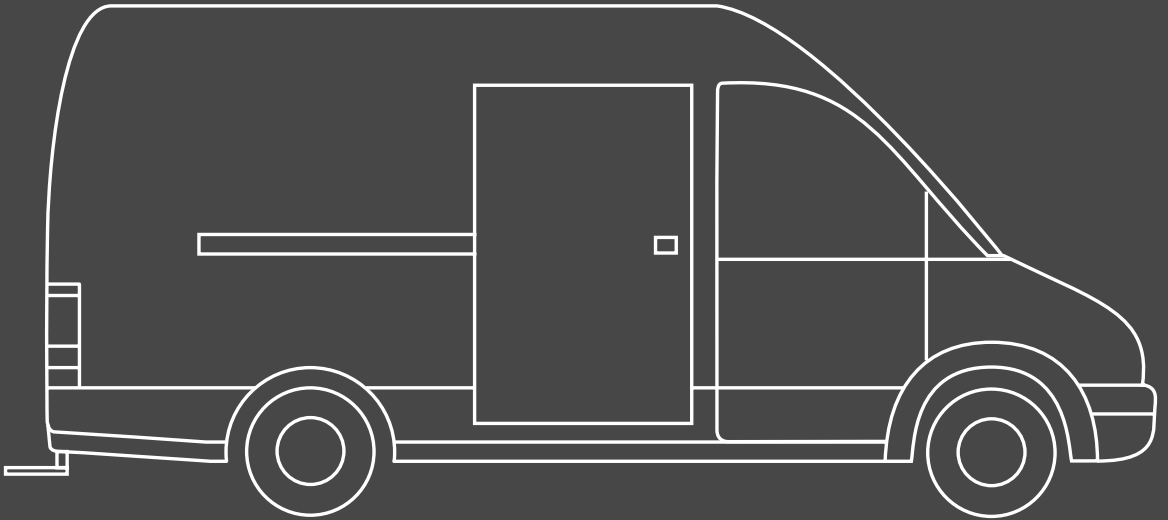

PANEL VAN SHELF CONVERSION
FIAT DUCATO

SOMMER®

EINFACH **SICHER** TRANSPORTIEREN.

TECHNICAL DATA

Chassis: FIAT Ducato Super High
 Wheel base: 4035 mm
 Perm. total weight: 3500 kg

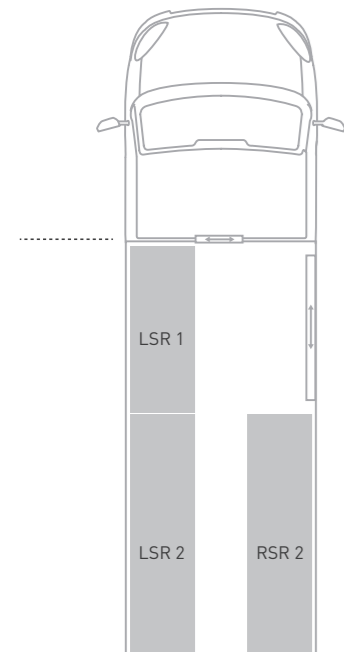
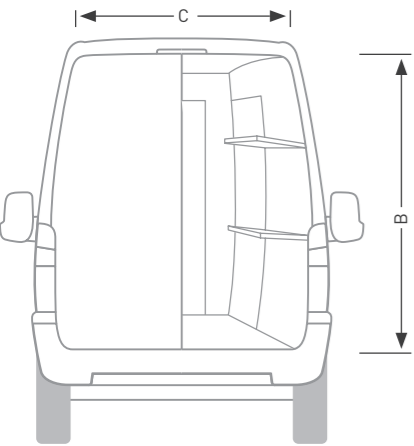
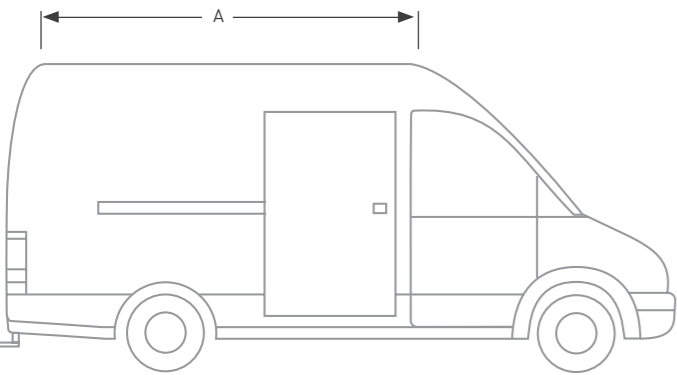

| Version | FIAT Ducato Super High |
|---|------------------------|
| Perm. total weight of vehicle | 3,5 t |
| Wheel base | 4035 mm |
| Max. payload including shelf conversion | 1000 kg -1250 kg |
| Sliding door on driver's cab | |
| Clearance height | 1800 mm |
| Passage width | 500 mm |
| Loading area/shelves | |
| A. Usable internal length of the loading area | 3990 mm |
| B. Usable internal height of the loading area | 2180 mm |
| C. Usable internal width of the loading area | 1580 mm |
| Total volume of the loading area | 11,70 m ³ |
| Shelf length LSR 1 | 1250 mm |
| Shelf length LSR 2 | 1800 mm |
| Shelf length RSR | 1800 mm |
| Depth of the lower shelf | 550 mm |
| Depth of the top shelf floor | 520 mm |
| Width of central gangway | 600 mm |
| Rear access step | |
| Height from ground to the rear access step | 345 mm |

STANDARD SCOPE OF DELIVERY



Thanks to its optimum utilization of space, the SOMMER TA panel van shelf conversion provides generous storage possibilities not only in the shelves themselves but also for bulk items. A robust design with a 200 kg loading capacity per shelf and a stable partition wall along with a lockable sliding door are a matter of course with SOMMER.

In addition, you receive the payload-optimized SUMMER TA with practical top-quality equipment as standard: LED interior lighting, integrated Airline lashing rails for securing loads and much more.

See for yourself:



Driver's cab

- 1.90 m standing height due to special roof height.
- Foldable passenger seat.
- Floor complete with aluminium checkered plate in entrance/exit area.



Partition wall

- Partition wall is made of anodised hollow profiles featuring a riveted construction method.
- Sliding door comprised of high-strength, noise-absorbant sandwich panel with a clear through-passage width of approx. 500 mm, clear through-passage height approx. 1,800 mm.
- Partition wall and door in compliance with DIN 75410.

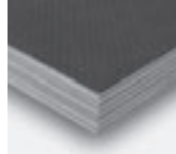

Floor

- Multi-layered panel flooring made of birch with a rough surface.



Shelves

- 4 rows of shelving on the driver's side, 2 rows of shelving on the passenger side, all shelves individually foldable, made of extruded aluminium profiles.
- 200 kg loading capacity per shelf.
- Shelf width approx. 520 mm - 550 mm.

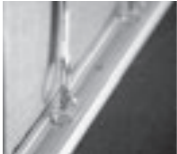

Load-securing

- Airline lashing rails on the shelves themselves as well as on the loading area floor. Rails correspond to DIN75410 and VDI 2700, Sheet 15.
- Lashing point loading capacity 50daN.
- Shelves complete with integrated safety edge.
- 6 lashing rings embedded in the floor.



Electrics

- LED loading area interior lights, mounted in the roof along the gangway, activated through movement sensors.

SPECIAL EQUIPMENT



- Nets installed between the shelving for load-securing.
- Non-slip mats fixed to shelves.
- Locking system with automatic closing mechanism for the partition wall sliding door, laterally-positioned sliding door and rear door. Unlocking via the vehicle's central locking system.
- Rear access step with non-slip tread.
- Reversing camera with monitor.



3990 mm

SAFE TRANSPORT MADE EASY.

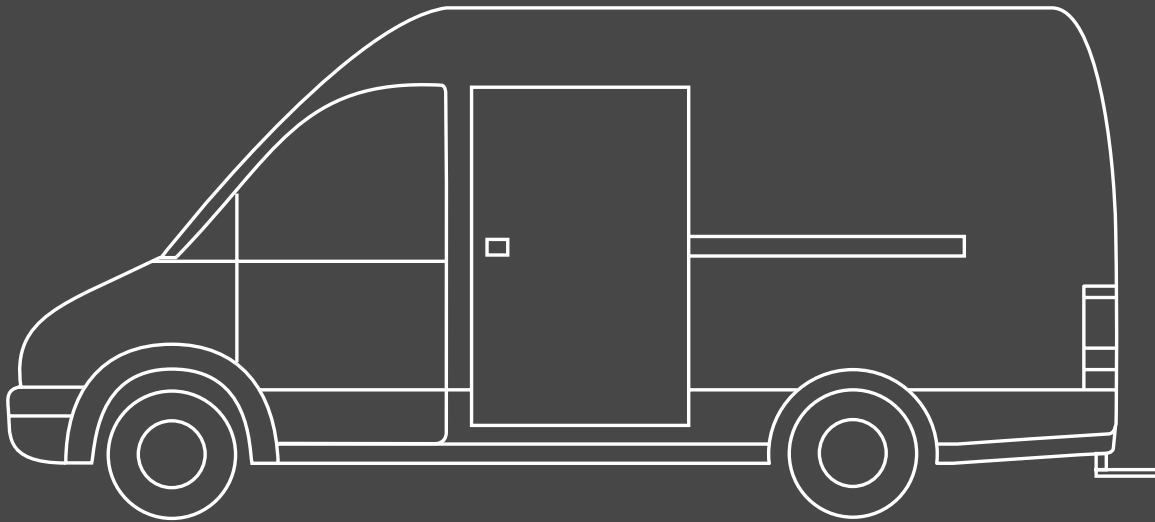

SOMMER®

SOMMER GMBH

Kleine Ziegelohstraße 8
D-06636 Laucha/Germany

Phone +49 (0)34462 580-0

Fax +49 (0)34462 580-71

info@sommer-online.de
www.sommer-online.de

Stand 10/2012. We reserve the right to alter the design and equipment; errors excepted. All specifications without guarantee. Vehicles featured in the images may be equipped with special equipment. Any decoration shown is not included in the scope of delivery.