

TIL

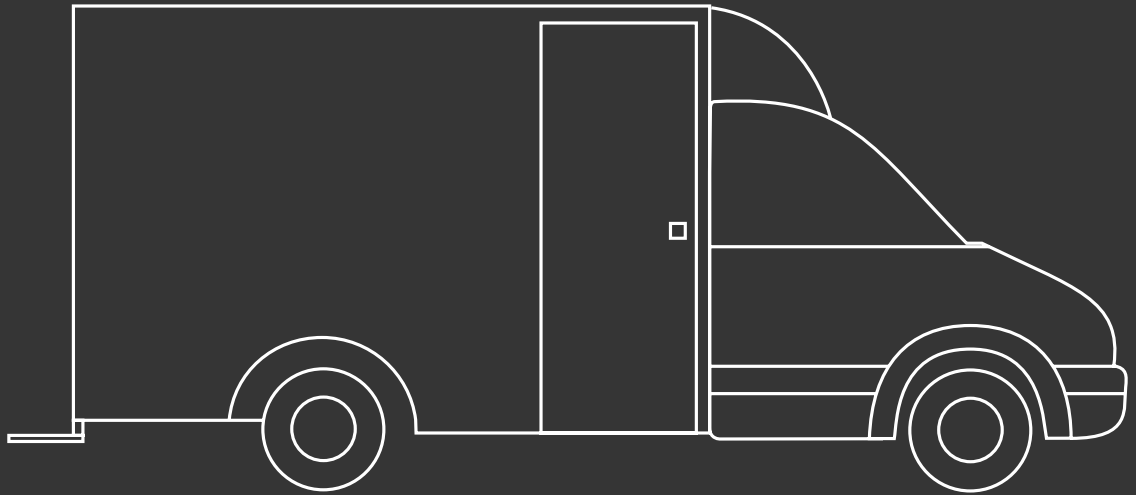

INTEGRAL WALK-IN BODY FOR VAN CHASSIS
FROM 3.5 T TO 5.0 T

IVECO DAILY

SOMMER®

EINFACH **SICHER** TRANSPORTIEREN.

TECHNICAL DATA

Chassis: IVECO Daily
 Wheel base: 3450 mm, 3750 mm, 4350 mm, 4800 mm
 Perm. total weight: 3500 kg, 5000 kg

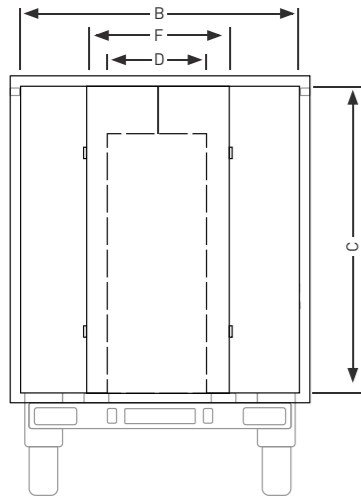
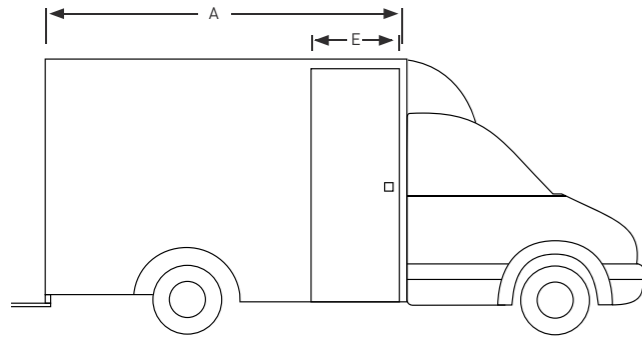

Permissible total vehicle weight	3,5 t
Design	TIL45
Wheelbase	3450 mm
Body volume m ³	14,45
Body weight	695 kg
A. Internal length	3500 mm
B. Internal width	2020 mm
C. Internal height to bottom edge of crossmember	2030 mm
D. Sliding partition door (clear wxh)	610 mm x 1900 mm
E. Lateral sliding door (clear wxh)	850 mm x 1900 mm
F. Rear door (clear wxh)	1000 mm x 1900 mm

Permissible total vehicle weight	3,5 t
Design	TIL60
Wheelbase	3750 mm
Body volume m ³	17,6
Body weight	795 kg
A. Internal length	4300 mm
B. Internal width	2020 mm
C. Internal height to bottom edge of crossmember	2030 mm
D. Sliding partition door (clear wxh)	610 mm x 1900 mm
E. Lateral sliding door (clear wxh)	850 mm x 1900 mm
F. Rear door (clear wxh)	1000 mm x 1900 mm

Permissible total vehicle weight	5,0 t
Design	TIL60
Wheelbase	3750 mm
Body volume m ³	17,6
Body weight	795 kg
A. Internal length	4300 mm
B. Internal width	2020 mm
C. Internal height to bottom edge of crossmember	2030 mm
D. Sliding partition door (clear wxh)	610 mm x 1900 mm
E. Lateral sliding door (clear wxh)	850 mm x 1900 mm
F. Rear door (clear wxh)	1000 mm x 1900 mm

Permissible total vehicle weight	5,0 t
Design	TIL70
Wheelbase	4350 mm
Body volume m ³	19,70
Body weight	865 kg
A. Internal length	4800 mm
B. Internal width	2020 mm
C. Internal height to bottom edge of crossmember	2030 mm
D. Sliding partition door (clear wxh)	610 mm x 1900 mm
E. Lateral sliding door (clear wxh)	850 mm x 1900 mm
F. Rear door (clear wxh)	1000 mm x 1900 mm

Permissible total vehicle weight	5,0 t
Design	TIL80
Wheelbase	4800 mm
Body volume m ³	22,5
Body weight	975 kg
A. Internal length	5500 mm
B. Internal width	2020 mm
C. Internal height to bottom edge of crossmember	2030 mm
D. Sliding partition door (clear wxh)	610 mm x 1900 mm
E. Lateral sliding door (clear wxh)	850 mm x 1900 mm
F. Rear door (clear wxh)	1000 mm x 1900 mm

STANDARD SCOPE OF DELIVERY



The integral walk-in body **SOMMER TIL** optimised for courier, express and parcel services offers everything you need for efficient deliveries: a large loading area, non-slip storage thanks to shelves with safety lip, broad gangways and lockable doors.

Moreover, the payload-optimised integrated light-weight walk-inbody for van chassis comes as standard with top practical equipment: LED interior lighting, integrated lashing rails and much more.

See for yourself:



Driver's Cab

- Aerodynamic high driver's cab roof with 1.90 m headroom.
- Folding passenger seat.
- Floor with aluminium checkered plate in the passway.



Shelves

- 4 shelves fixed on driver's side, 2 individually folding shelves on passenger side, made of aluminium extruded sections.
- Load 250 kg/shelf, depth approx. 570 mm



Partition Wall

- Partition wall of anodised hollow profiles in rivet construction.
- Sliding door of high-strength, noise-absorbing sandwich panel.
- 610 mm clear width and approx. 1,900 mm clearheight in gangway.
- Partition wall and door comply with DIN 75410.



Cargo control

- Airline lashing rails on the shelves and on the floor. Rails comply with DIN75410 and VDI 2700, Sheet 15.
- Capacity of lashing points 50daN.
- Shelves with safety edge.



Body

- Body riveted/bonded.
- Side walls and rear wall of 17-mm-thick special plastic panels, enclosed in aluminium profiles.
- Rear and side sliding door of high-strength sandwich panel
- Side sliding door with integrated step tread, doorway approx. 850 mm x 1,900 mm.
- Rear doors fitted flush, doorway approx. 1,000 mm x 1,900 mm.
- Rear door wings stopped in open position by rubber buffer.
- Aluminium rear step complies with accident prevention regulations (UVV), step depth 300 mm.
- Floor of plywood panels laminated with phenolic resin, with non-slip screen-printed surface.



Automatic locking system

- Locking system with automatic locking mechanism for sliding partition door, side sliding door and rear door. Release via the vehicle's central locking.

Electrics

- 1 interior LED light in driver's cab, can be turned on when ignition is off.
- 3 interior LED lights in the body, fitted in the aisle under the ceiling, controlled by motion sensors.

SPECIAL EQUIPMENT

- Reversing camera with monitor
- Folding shelves on the driver's side
- Nets between the shelves
- Non-slip mats on the shelves
- Spare wheel holder in the body

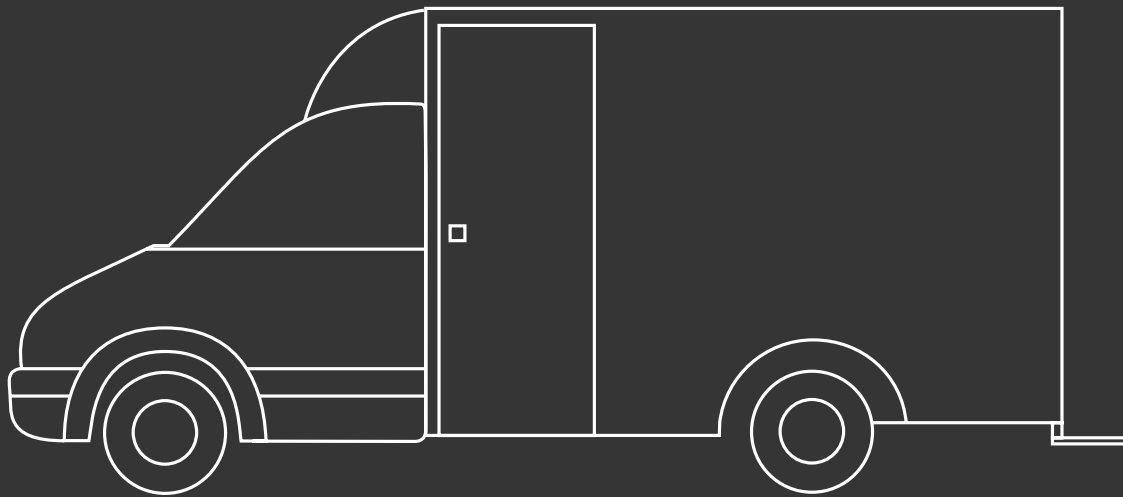

SOMMER®

SOMMER GMBH
Kleine Ziegelohstraße 8
D-06636 Laucha/Germany

Phone +49 (0)34462 580-0
Fax +49 (0)34462 580-71

info@sommer-online.de
www.sommer-online.de

Stand 10/2013. We reserve the right to alter the design and equipment; errors excepted. All specifications without guarantee. Vehicles featured in the images may be equipped with special equipment. Any decoration shown is not included in the scope of delivery.